

## Modular Cooking Range Line thermaline 80 - Electric Free-cooking Top on Warming Cabinet H=800

ITEM # \_\_\_\_\_

MODEL # \_\_\_\_\_

NAME # \_\_\_\_\_

SIS # \_\_\_\_\_

AIA # \_\_\_\_\_



**588471 (MATHFAH4AO)** Electric Free-Cooking Top, one-side operated, on Warming Cabinet

### Short Form Specification

#### Item No.

Unit constructed according to DIN 18860\_2 with 20 mm drop nose top. Internal frame for heavy duty sturdiness in stainless steel. 2 mm top in 1.4301 (AISI 304). Flat surface construction, easily cleanable. THERMODUL connection system enables seamless worktop when units are connected and avoids soil penetrating. Smooth electrically-heated solid plate made of 20 mm thick steel with a wide rounded cleaning zone around the plate. Rapid plate heat up, continuously ready to use; maximum reachable surface temperature of 350°C. Overheat protection switches off the supply in case of overheating. Standby function saves energy and quickly recovers maximum power. Metal knobs with embedded hygienic silicon "soft" grip enable easier handling and cleaning. 800 mm wide warming cabinet with 2 doors, constructed according to DIN 18860\_2 with 70 mm recessed plinth. Internal frame for heavy duty sturdiness in stainless steel. 2 mm top in 1.4301 (AISI 304). Flat surface construction, easily cleanable. THERMODUL connection system enables seamless worktop when units are connected and avoids soil penetrating. Temperature in the cabinet can be set through thermostat, up to a maximum of 110 °C. Cabinet storage space accepts GN 1/1 containers. IPX5 water resistance certification.

### Main Features

- Rapid heat up of the plate and continuously ready for use.
- Overheat protection: the temperature sensor switches off the supply in case of overheating.
- Stainless steel high splash guards on the rear and sides of cooking surface.
- Wide rounded cleaning zone around the plates for easier cleaning.
- All major components may be easily accessed from the front.
- THERMODUL connection system creates a seamless work top when units are connected to each other thus avoiding soil penetrating vital components and facilitating the removal of units in case of replacement or service.
- Metal knobs with embedded hygienic "soft-touch" grip for easier handling and cleaning. The special design of the controls prevents infiltration of liquids or soil into vital components.
- Large visible digital display manufactured in tempered glass to resist heat and chemicals, showing temperatures or power settings. The display also shows on/off status of the appliance and on/off status of the heating elements.
- Cooking plate and base joint profile guarantee against soil infiltration.
- Surface temperature up to 350°C
- Unit constructed according to DIN 18860\_2 with 70 mm recessed plinth.
- For direct and indirect cooking.
- Temperature in the cupboard can be set through a thermostat to suit different requirements. The maximum temperature is 110°C.

### Construction

- 2 mm top in 1.4301 (AISI 304).
- Unit constructed according to DIN 18860\_2 with 20 mm drop nose top and 70 mm recessed plinth.
- Flat surface construction with minimal hidden areas to easily clean all surfaces
- IPX5 water resistance certification.
- Storage space in the base of the appliance accepts GN1/1 containers.
- Unit constructed according to DIN 18860\_2 with 20 mm drop nose top.
- Cooking surface is an electrically heated solid plate made from 20 mm thick stainless steel AISI 316 - DIN 1.4404.
- 2mm thick top in stainless steel AISI 304 - DIN 1.4301.

APPROVAL: \_\_\_\_\_

- Internal frame for heavy duty sturdiness in stainless steel.

## Sustainability



- Standby function for energy saving and fast recovery of maximum power.

## Optional Accessories

- Connecting rail kit, 800mm PNC 912500
- Stainless steel side panel, 800x800mm, freestanding PNC 912508
- Stainless steel front kicking strip, 800mm width PNC 912598
- Stainless steel side kicking strips left and right, freestanding, 800mm width PNC 912619
- Stainless steel side kicking strips left and right, back-to-back, 1610mm width PNC 912625
- Stainless steel plinth, freestanding, 800mm width PNC 912825
- Connecting rail kit: modular 80 (on the left) to ProThermetic tilting (on the right), ProThermetic stationary (on the left) to ProThermetic (on the right) PNC 912971
- Connecting rail kit: modular 80 (on the right) to ProThermetic tilting (on the left), ProThermetic stationary (on the right) to ProThermetic (on the left) PNC 912972
- Endrail kit, flush-fitting, left PNC 913109
- Endrail kit, flush-fitting, right PNC 913110
- Scraper for smooth plates PNC 913119
- Endrail kit (12.5mm) for thermaline 80 units, left PNC 913200
- Endrail kit (12.5mm) for thermaline 80 units, right PNC 913201
- Stainless steel side panel, left, h=800 PNC 913216
- Stainless steel side panel, right, h=800 PNC 913217
- Insert profile D=800mm PNC 913230
- Perforated shelf for warming cabinets and cupboard bases (one-side operated TL80-85-90 and two-side operated for TL80) PNC 913234
- Energy optimizer kit 32A - factory fitted PNC 913247
- Endrail kit, (12.5mm), for back-to-back installation, left PNC 913249
- Endrail kit, (12.5mm), for back-to-back installation, right PNC 913250
- Endrail kit, flush-fitting, for back-to-back installation, left PNC 913253
- Endrail kit, flush-fitting, for back-to-back installation, right PNC 913254
- Side reinforced panel only in combination with side shelf, for freestanding units PNC 913257
- Side reinforced panel only in combination with side shelf, for back-to-back installations, left PNC 913273
- Side reinforced panel only in combination with side shelf, for back-to-back installation, right PNC 913274

- Shelf fixation for TL80-85-90 one-side operated, TL80 two-side operated PNC 913281
- Filter W=800mm PNC 913665
- Stainless steel dividing panel, 800x800mm, (it should only be used between Electrolux Professional thermaline Modular 80 and thermaline C80) PNC 913669
- Electric mainswitch 63A 10mm<sup>2</sup> NM for modular H800 electric units (factory fitted) PNC 913677
- Stainless steel side panel, 800x800mm, flush-fitting (it should only be used against the wall, against a niche and in between Electrolux Professional thermaline and ProThermetic appliances and external appliances - provided that these have at least the same dimensions) PNC 913685

**Recommended Detergents**

- C41 HI-TEMP RAPID DEGREASER, 1 pack of six 1 lt. bottles (trigger incl.) PNC 0S2292

Front

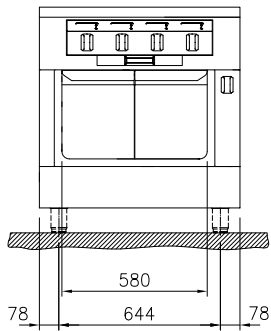

Side

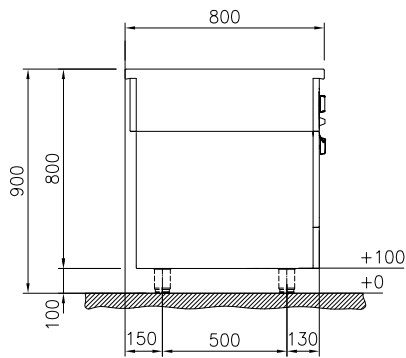

EI = Electrical inlet (power)  
EQ = Equipotential screw

Top

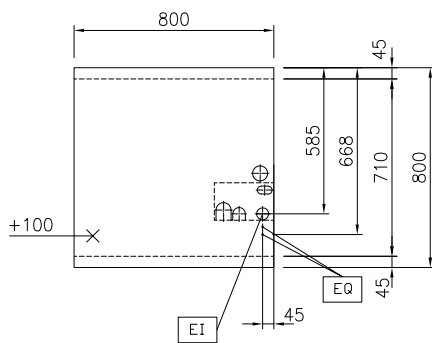

**Electric**

Supply voltage: 400 V/3N ph/50/60 Hz  
Electrical power, max: 14.3 kW

**Key Information:**

Working Temperature MIN: 80 °C  
Working Temperature MAX: 350 °C  
External dimensions, Width: 800 mm  
External dimensions, Depth: 800 mm  
External dimensions, Height: 800 mm  
Storage Cavity Dimensions (width):  
Storage Cavity Dimensions (height):  
Storage Cavity Dimensions (depth): 0 mm  
Net weight: 143 kg  
Configuration: On Oven; One-Side Operated  
Front Plates Power: 3 - 3 kW  
Back Plates Power: 3 - 3 kW  
Solid top usable surface (width): 670 mm  
Solid top usable surface (depth): 650 mm

**Sustainability**

Current consumption: 30.5 Amps